

MV15G Series

15W, Wide 2:1 Input, 1.5KV Isolation, DIP1"x1" DC/DC Converters



Features

- Rated power: 15W Max
- Input voltage range 2:1
- Regulated single or dual out
- High efficiency up to 91%
- Isolation voltage 1.5KVDC
- Remote On/Off control
- Output trimming $\pm 10\%$
- Operating temperature range: -40 ~ +85°C ambient
- RoHS compliant
- Compact 1"x1" package
- Under voltage, over voltage, over current, and short circuit protection
- Meet IEC/EN/UL 62368-1 CISPR32, EN55032
- 3 year warranty



Overview

The MV15G series are 1.5KV isolated 15Watt DC/DC converters with standard DIP1"x1" footprint. Designed with high efficiency, they operate in a wide temperature range from -40°C to +85°C. Other features include wide 2:1 input voltage range, remote on/off control, under voltage, over voltage, over current, and short circuit protections. These converters are ideally suitable for battery operated equipment, measurement equipment, telecom, wireless network, industrial control system.

Model Numbers

Model Number	Input Voltage [VDC]			V _{OUT} [VDC]	Output Current [mA]		Efficiency [%] Typ.	Capacitive Load [μ F] Max.
	Nom.	Range	*Max.		Max.	Min.		
MV15G-1203	12	9~18	20	3.3	4000	0	88	4700
MV15G-1205	12	9~18	20	5.0	3000	0	90	4700
MV15G-1212	12	9~18	20	12	1250	0	90	1000
MV15G-1215	12	9~18	20	15	1000	0	91	820
MV15G-1224	12	9~18	20	24	625	0	91	820
MV15G-1248	12	9~18	20	48	313	0	89	100
MV15G-1205D	12	9~18	20	± 5	± 1500	0	89	1500
MV15G-1212D	12	9~18	20	± 12	± 625	0	89	470
MV15G-1215D	12	9~18	20	± 15	± 500	0	91	330
MV15G-2403	24	18~36	40	3.3	4000	0	88	4700
MV15G-2405	24	18~36	40	5	3000	0	89	4700
MV15G-2412	24	18~36	40	12	1250	0	89	1000
MV15G-2415	24	18~36	40	15	1000	0	91	820
MV15G-2424	24	18~36	40	24	625	0	91	820
MV15G-2405D	24	18~36	40	± 5	± 1500	0	89	1500
MV15G-2412D	24	18~36	40	± 12	± 625	0	89	470
MV15G-2415D	24	18~36	40	± 15	± 500	0	91	330

MV15G Series

15W, Wide 2:1 Input, 1.5KV Isolation, DIP1"X1" DC/DC Converters



Model Numbers [continued]

Model Number	Input Voltage [VDC]			V _{OUT} [VDC]	Output Current [mA]		Efficiency [%] Typ.	Capacitive Load [uF] Max.
	Nom.	Range	*Max.		Max.	Min.		
MV15G-4803	48	36~75	80	3.3	4000	0	88	4700
MV15G-4805	48	36~75	80	5	3000	0	90	4700
MV15G-4812	48	36~75	80	12	1250	0	91	1000
MV15G-4815	48	36~75	80	15	1000	0	91	820
MV15G-4824	48	36~75	80	24	625	0	91	820
MV15G-4805D	48	36~75	80	±5	±1500	0	89	1500
MV15G-4812D	48	36~75	80	±12	±625	0	89	470
MV15G-4815D	48	36~75	80	±15	±500	0	91	330

* Only typical models are listed. Other models may be available upon request.

* Input voltage exceed the Max. value may cause permanent damage.

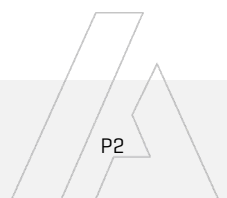

Electrical Specifications

Unless otherwise indicated, specifications are measured at $T_A=25^{\circ}\text{C}$, nominal input voltage, full load after warm up.

Parameters	Conditions	Min.	Typ.	Max.	Unit	Note
Input voltage surge 1 second max	$V_{IN, Nom} = 12\text{V}$	-0.7		25	VDC	
	$V_{IN, Nom} = 24\text{V}$	-0.7	-	50		
	$V_{IN, Nom} = 48\text{V}$	-0.7		100		
Startup input voltage	$V_{IN, Nom} = 12\text{V}$			9.0	VDC	
	$V_{IN, Nom} = 24\text{V}$			18		
	$V_{IN, Nom} = 48\text{V}$			36		
Input under voltage shutdown	$V_{IN, Nom} = 12\text{V}$	5.5	6.5		VDC	
	$V_{IN, Nom} = 24\text{V}$	12	15.5	-		
	$V_{IN, Nom} = 48\text{V}$	26	30			
Startup time			10		mS	
Remote On/Off control "Ctrl" pin open or logic high [ON] "Ctrl" pin grounded or logic low [OFF]	Logic high	3.5	-	12	VDC	Positive Logic
	Logic low	0	-	1.2	VDC	
	Ctrl pin current	-	5	8	mA	
Output voltage accuracy	$I_{OUT}=0$ to 100%	-	± 1	± 3	%	
Line regulation Full load, $V_{IN}=V_{IN, Min}$ to $V_{IN, Max}$	Main Out	-	± 0.2	± 0.5	%	
	Others		± 0.5	± 1.0		
Load regulation $I_{OUT}=5\%$ to 100% of $I_{OUT, rated}$	Main Out	-	± 0.5	± 1.0	%	
	Others		± 0.5	± 1.5		
Cross regulation $+I_{OUT}=50\%$, $-I_{OUT}=10\%$ to 100%	Dual output models	-	-	± 5	%	
Output ripple and noise 20MHz bandwidth, peak to peak		-	50	100	mVp-p	
Temperature coefficient	Full load	-	-	± 0.03	%/ $^{\circ}\text{C}$	
Dynamic load response $I_{OUT}=25\% \sim 50\% \sim 75\%$ of $I_{OUT, rated}$	Peak deviation	-	± 3	± 8	% V_{OUT}	
	Recovery time		300	500	μS	
Output voltage trim	Trim range	-	-	± 10	% V_{OUT}	
Output over voltage protection		110		160	% V_{OUT}	
Output over current protection		110	150	190	% I_{OUT}	
Output short circuit protection		Continuous, automatic recovery				
Input filter		PI filter				
Hot plug		None				

* Operating with less than 5% of rated load will not cause damage to the converters, but the performances data may not fall into the specifications, and stable operating is not assured.

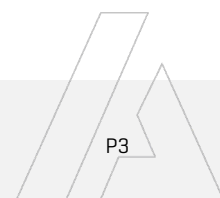

MV15G Series

15W, Wide 2:1 Input, 1.5KV Isolation, DIP1"X1" DC/DC Converters



General Specifications

Parameters	Conditions	Min.	Typ.	Max.	Unit	Note
Isolation voltage 1 minute, leakage current 1mA max.	I/P to O/P	1500	-	-	VDC	
Isolation resistance Tested at 500VDC	I/P to O/P	1000	-	-	M ohm	
Isolation capacitance 100KHz, 0.1V	I/P to O/P	-	1000	-	pF	
Switching frequency	Full load	-	300	-	KHz	PWM mode
Operating temperature		-40	-	+85	°C	
Storage temperature		-55	-	+125	°C	
Storage humidity	None condensing	5	-	95	%RH	
Pin soldering resistance 1.5mm away from case for 10 sec		-	-	+300	°C	
Cooling method		Free air convection				
Case material		Aluminum alloy				
Vibration		IEC/EN61373 – Category 1, Grade B				
MTBF	MIL-HDBK-217F	>1,000,000 Hours, T _A =25°C				
Design based on standards		UL/EN/IEC 62368-1				
Safety certifications		EN/IEC 62368-1				
EMC		CISPR32, EN55032 Class B with external circuit IEC/EN61000-4-2, 3, 4, 5, 6				
Size, and Weight		25.4 x 25.4 x 12mm, 16g				

* Switching frequency is measured at full load. The converter reduces the switching frequency at low load [less than 50% load] for better efficiency.

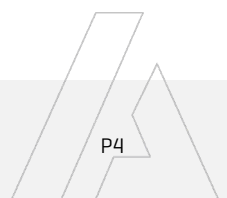

MV15G Series

15W, Wide 2:1 Input, 1.5KV Isolation, DIP1"X1" DC/DC Converters



Characteristic Curves

Derating Curve

Output vs Ambient Temperature

$V_{OUT}=3.3 \dots 5V$

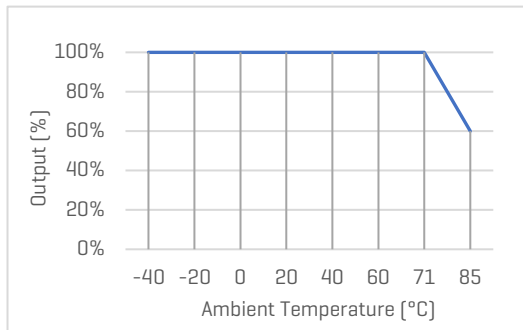

$V_{OUT}=12 \dots 24V$

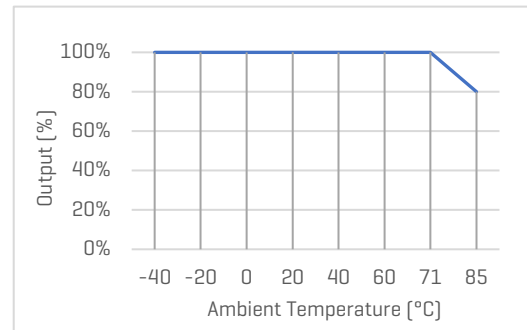

Efficiency Curve

Efficiency vs Input Voltage

MV15G-2405, with full Load

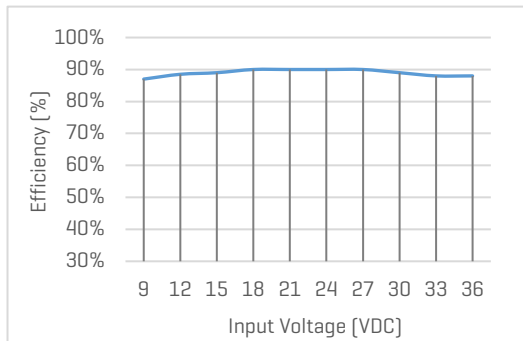

Efficiency vs Load

MV15G-2405, with nominal input voltage

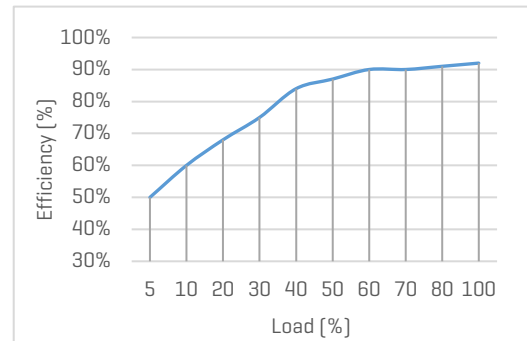

MV15G-4805, with full Load

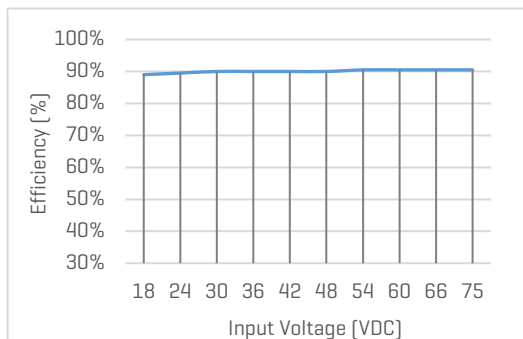

MV15G-4805, with nominal input voltage

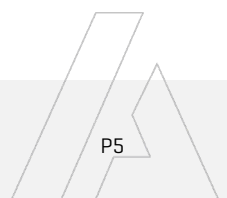
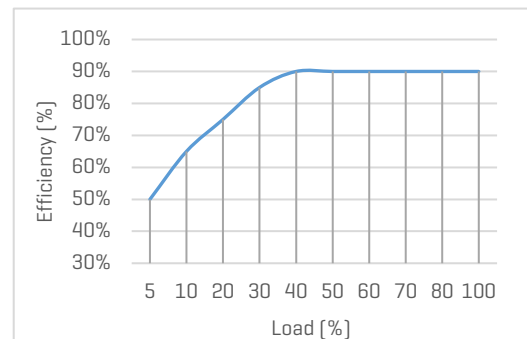

MV15G Series

15W, Wide 2:1 Input, 1.5KV Isolation, DIP1"X1" DC/DC Converters



Recommended Application Circuit

Typical Application Circuit

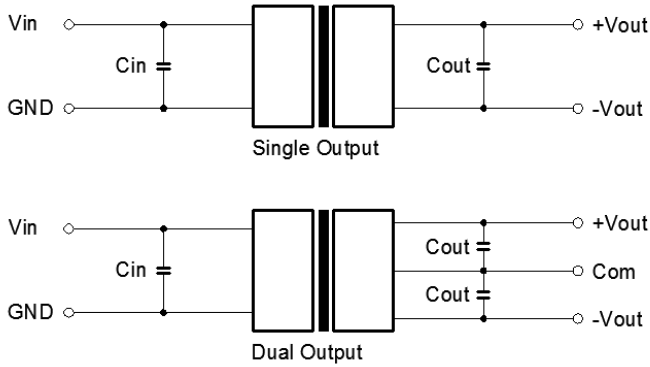

Note

*Typical application circuit is to further lower the input and output ripple. It is not required for general use.

*Recommended component specifications are typical values. Excessive external capacitive load may cause startup problem.

[Table 1] Recommended component spec

C_{IN}	100uF
C_{OUT}	47...100uF

Figure 1. Typical external circuit

EMC Enhancement for EN55032 Class B

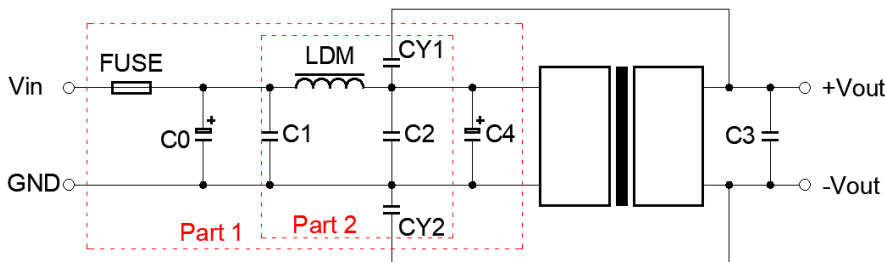

Figure 2. Circuit for EMC enhancement

[Table 2] Recommended component spec

Item	LDM	C0, C4	C1, C2	CY1, CY2
Spec	2.2uH	330uF, 100V	4.7uF, 100V	1nF, 2KV

* Fuse to be selected according to application needs.

* C3 refer to relative C_{OUT} values in Table 1.

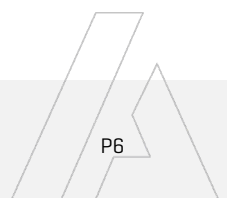

Recommended Application Circuit [continued]

Circuits for Output Trim

* Items in the red blocks are internal components of the converter.

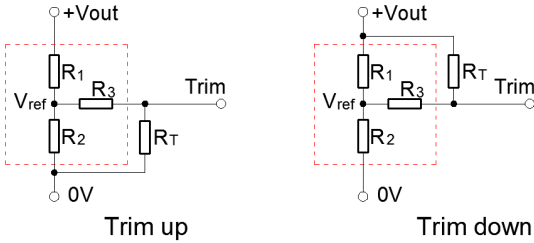

* The formulas to calculate the desired resistance of Trim resistor "RT".

$$\text{Trim up: } R_T = \frac{a R_2}{R_2 - a} - R_3 \quad a = \frac{V_{ref}}{V_{OUT} - V_{ref}} R_1$$

$$\text{Trim down: } R_T = \frac{a R_1}{R_1 - a} - R_3 \quad a = \frac{V_{OUT} - V_{ref}}{V_{ref}} R_2$$

[Table 3] Internal component spec

V _{OUT} [V]	R1 [K Ohm]	R2 [K Ohm]	R3 [K Ohm]	V _{ref} [V]
3.3	10	6.064	13.622	1.24
5	2.4	2.344	17.346	2.5
12	8.2	2.153	21.016	2.5
15	12	2.388	21.016	2.5
24	10	1.158	10.714	2.5

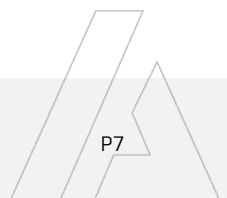

MV15G Series

15W, Wide 2:1 Input, 1.5KV Isolation, DIP1"X1" DC/DC Converters



Mechanical Specifications

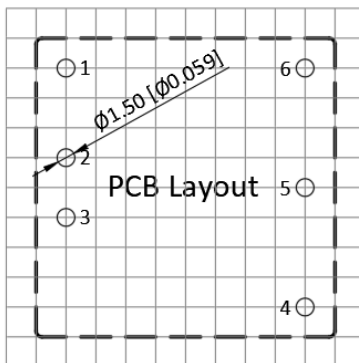
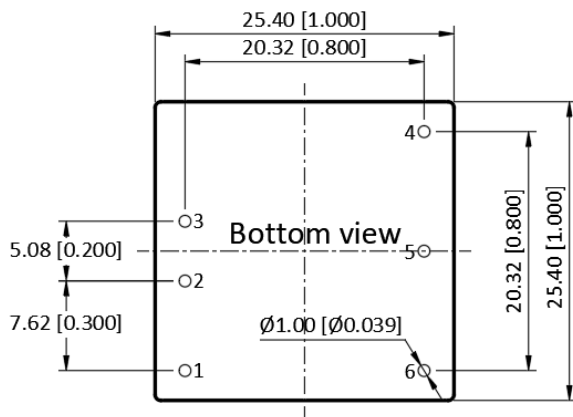
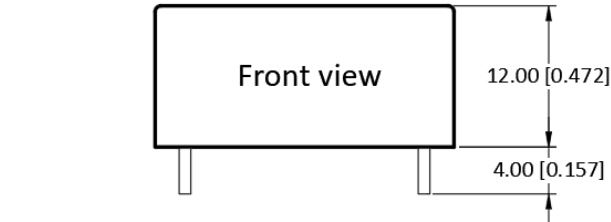

Pin Definition

Pin #	Single Out	Dual Out
1	Ctrl	Ctrl
2	GND	GND
3	V _{IN}	V _{IN}
4	+V _{OUT}	+V _{OUT}
5	Trim	0V
6	0V	-V _{OUT}

* Unless otherwise specified unit: mm [inch]

* General tolerance: ±0.50 [±0.020]

* Pin thickness: ±0.10 [±0.004]

* Footprint grid 2.54 x 2.54 mm